

TYPICAL ELEVATIONS

ANCHOR TYPE	ANCHOR SPACING INCHES	
	HEAD	SILL
A	9	9
B	9	11
C	9	11

THIS SYSTEM IS RATED FOR LARGE & SMALL MISSILE IMPACT. SHUTTERS ARE NOT REQUIRED.

APPROVAL APPLIES TO SINGLE LITE UNITS OR MULTIPLE LITES UNIT INSTALLATIONS
SEE SHEET 2 FOR DESIGN LOAD CAPACITY

SERIES 'SLIMPACT XJ' GLASS WALL SYSTEM

THIS PRODUCT HAS BEEN DESIGNED AND TESTED TO COMPLY WITH THE REQUIREMENTS OF THE 2020 (7TH EDITION) FLORIDA BUILDING CODE INCLUDING HIGH VELOCITY HURRICANE ZONE (HVHZ).

1BY OR 2BY WOOD BUCKS & BUCK FASTENERS BY OTHERS, MUST BE DESIGNED AND INSTALLED ADEQUATELY TO TRANSFER APPLIED PRODUCT LOADS TO THE BUILDING STRUCTURE.

ANCHORS SHALL BE CORROSION RESISTANT, SPACED AS SHOWN ON DETAILS AND INSTALLED PER MANUF'S INSTRUCTIONS. SPECIFIED EMBEDMENT TO BASE MATERIAL SHALL BE BEYOND WALL DRESSING OR STUCCO.

A LOAD DURATION INCREASE IS USED IN DESIGN OF ANCHORS INTO WOOD ONLY.

ALL SHIMS TO BE HIGH IMPACT, NON-METALLIC AND NON-COMPRESSIBLE.

MATERIALS INCLUDING BUT NOT LIMITED TO STEEL/METAL SCREWS, THAT COME INTO CONTACT WITH OTHER DISSIMILAR MATERIALS SHALL MEET THE REQUIREMENTS OF THE 2020 FLORIDA BLDG. CODE & ADOPTED STANDARDS.

THIS PRODUCT APPROVAL IS GENERIC AND DOES NOT PROVIDE INFORMATION FOR A SITE SPECIFIC PROJECT, i.e. LIFE SAFETY OF THIS PRODUCT, ADEQUACY OF STRUCTURE RECEIVING THIS PRODUCT AND SEALING AROUND OPENING FOR WATER INFILTRATION RESISTANCE ETC.

CONDITIONS NOT SHOWN IN THIS DRAWING ARE TO BE ANALYZED SEPARATELY, AND TO BE REVIEWED BY BUILDING OFFICIAL.

DESIGN LOADS SHOWN ARE BASED ON 'ALLOWABLE STRESS DESIGN (ASD)'.

MANUFACTURER'S LABEL SHALL BE LOCATED ON A READILY VISIBLE LOCATION IN ACCORDANCE WITH SECTION 1709.9.3 OF FLORIDA BUILDING CODE. LABELING TO COMPLY WITH SECTION 1709.9.2.

Sealed: 2/16/2021

FL #25673

- A- CONTRACTOR TO BE RESPONSIBLE FOR THE SELECTION, PURCHASE AND INSTALLATION OF THIS PRODUCT BASED ON THIS PRODUCT EVALUATION PROVIDED HE/SHE DOES NOT DEVIATE FROM THE CONDITIONS DETAILED ON THIS DOCUMENT.
- B- THIS PRODUCT EVALUATION DOCUMENT WILL BE CONSIDERED INVALID IF ALTERED BY ANY MEANS.
- C- SITE SPECIFIC PROJECTS SHALL BE PREPARED BY A FLORIDA REGISTERED ENGINEER OR ARCHITECT WHICH WILL BECOME THE ENGINEER OF RECORD (E.O.R.) FOR THE PROJECT AND WHO WILL BE RESPONSIBLE FOR THE PROPER USE OF THE P.E.D. ENGINEER OF RECORD, ACTING AS A DELEGATED ENGINEER TO THE P.E.D. ENGINEER SHALL SUBMIT TO THIS LATTER THE SITE SPECIFIC DRAWINGS FOR REVIEW.
- D- THIS P.E.D. SHALL BEAR THE DATE AND ORIGINAL SEAL AND SIGNATURE OF THE PROFESSIONAL ENGINEER OF RECORD THAT PREPARED IT.

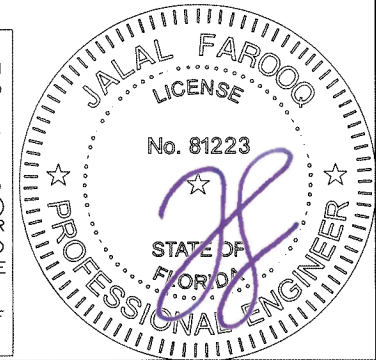

af c
AL-FAROOQ CORPORATION
 ENGINEERS & PRODUCT DEVELOPMENT
 9360 SUNSET DRIVE, SUITE 220 (C.A.N. 3538)
 MIAMI, FLORIDA 33173 TEL. (305) 264-8100 FAX. (305) 262-6978
 COMP-ANL \ 21-07F-FGT

SERIES 'SLIMPACT XJ' GLASS WALL SYSTEM (L.M.I.)

Faour Glass Technologies
 5119 West Knox Street
 Tampa, FL 33634
 Tel. (813) 884-3297 Fax. (-)

revisions:	no.	date	description
	01-25-21		
		scale: 3/8"=1'-0"	
		dr. by: TARIQ	
		chk. by:	
			drawing no.
			21-07F
			sheet 1 of 6

DESIGN LOAD CAPACITY - PSF			
D.L.O. DIMS.		LAM. INSUL. GLASS	
WIDTH	HEIGHT	EXT.(+)	INT.(-)
118"	234"	65.0	65.0
121-1/8"	228"	66.7	66.7
127-7/8"	216"	70.4	70.4
135-3/8"	204"	74.6	74.6
143-13/16"	192"	79.2	79.2
153-7/16"	180"	80.0	84.5
163-3/8"	169"	80.0	90.0

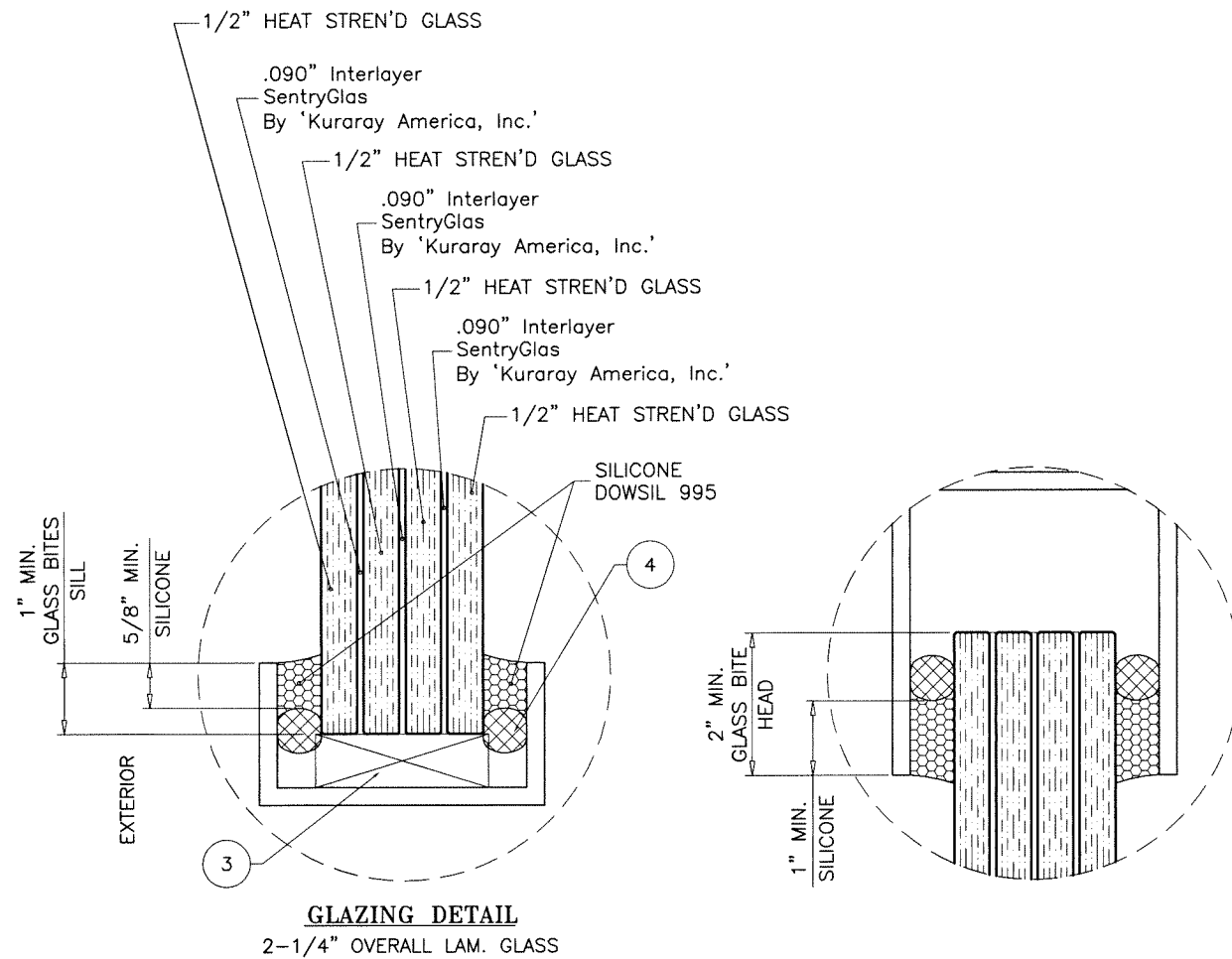
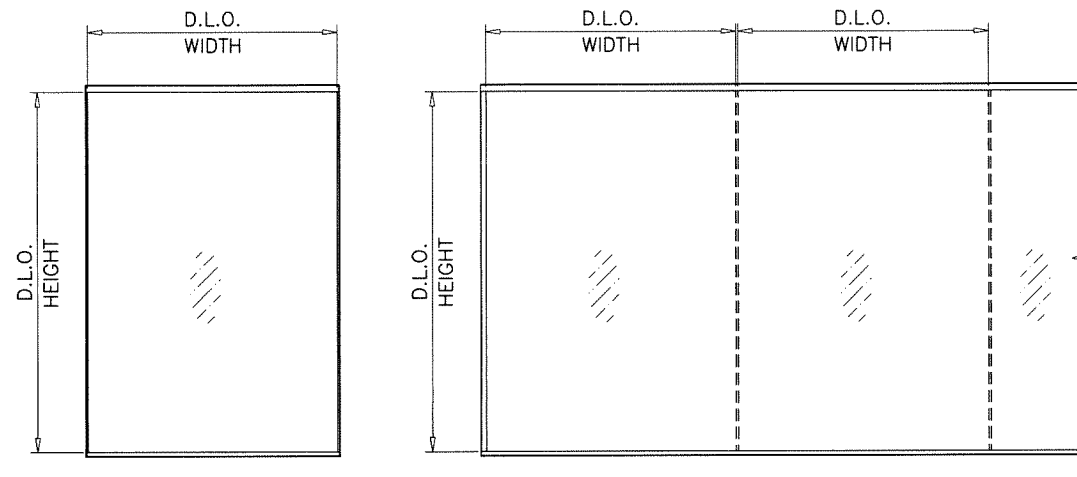

Sealed: 2/16/2021

FL #25673

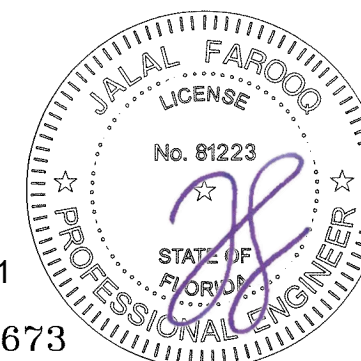

AL-FAROOQ CORPORATION
 ENGINEERS & PRODUCT DEVELOPMENT
 9360 SUNSET DRIVE, SUITE 220
 MIAMI, FLORIDA 33173
 TEL. (305) 264-8100 FAX. (305) 262-6978
 (C.A.N. 3538)

SERIES 'SLIMPACT XU' GLASS WALL SYSTEM (L.M.I.)
Faour Glass Technologies
 5119 West Knox Street
 Tampa, FL. 33634
 Tel. (813) 884-3297 Fax. (-)

revisions:	no.	date	by	description

date: 01-25-21	scale: 3/8" = 1"	dr. by: TARIO	chk. by:
drawing no. 21-07F			
sheet 2 of 6			

COMP-ANL\21-07F-FGT

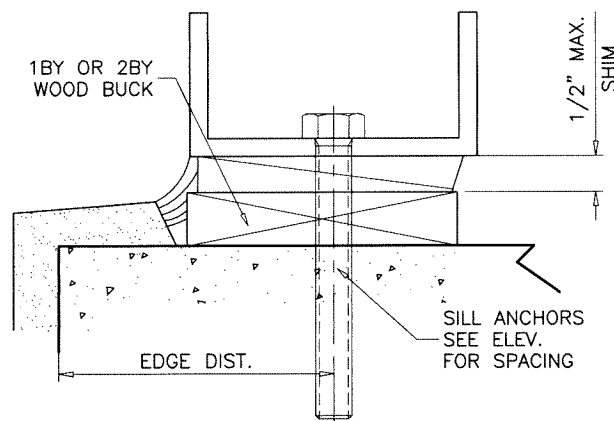
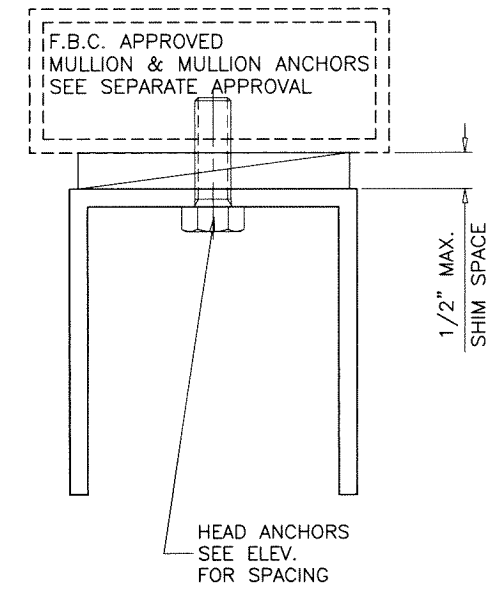
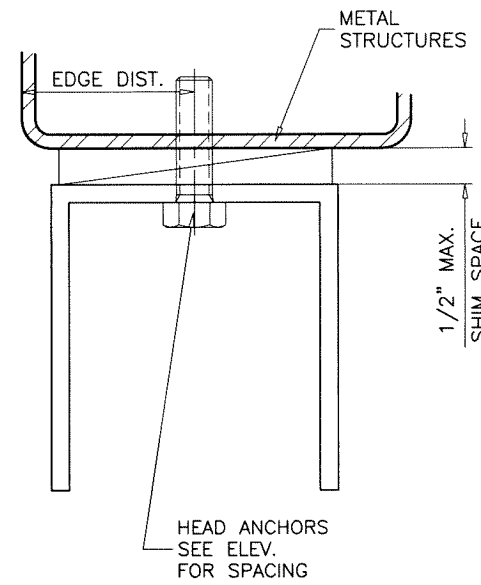
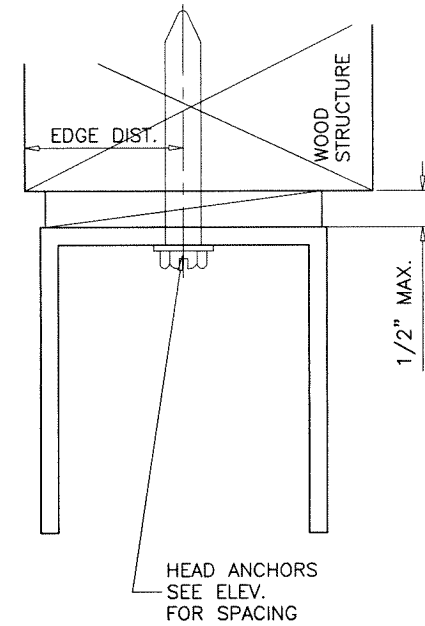
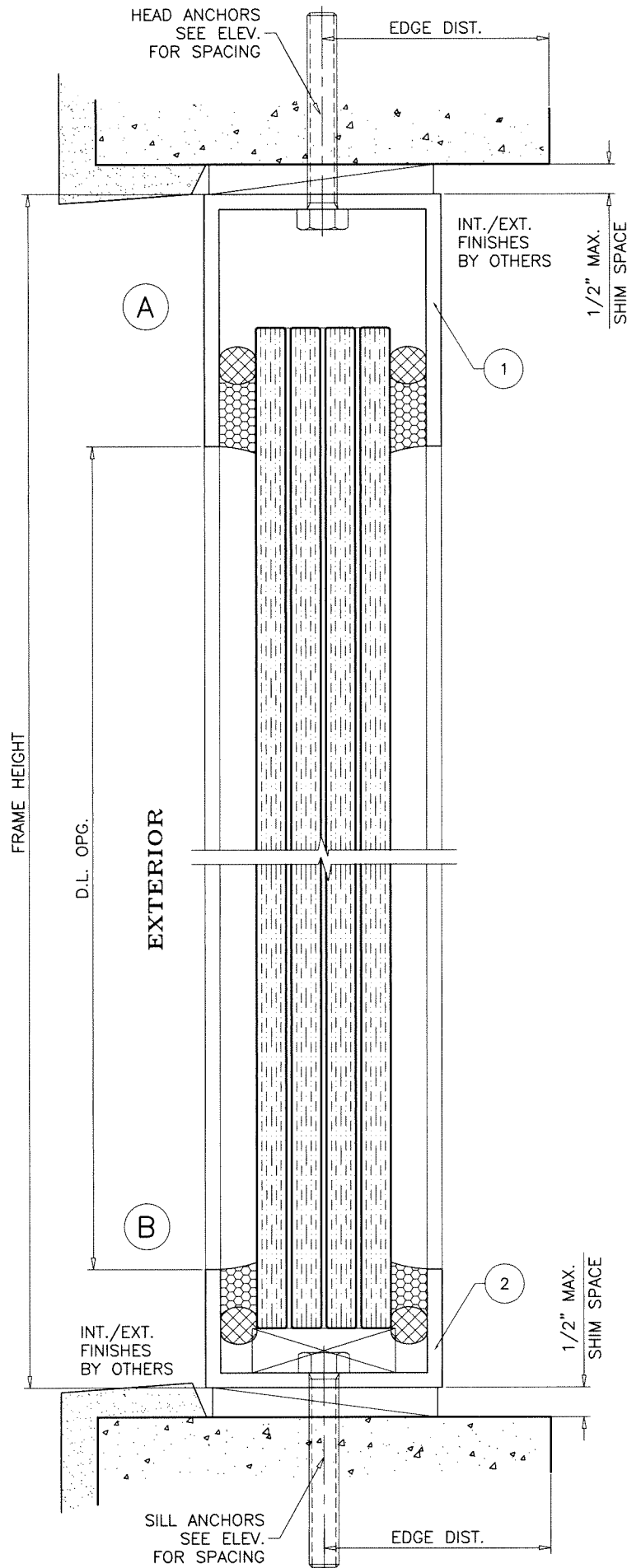

HEAD/SILL ANCHORS: SEE ELEV. FOR SPACING

- ANCHOR 'A'** - 1/2" DIA. LAG SCREWS
 INTO WOOD STRUCTURES
 3" MIN. PENETRATION INTO WOOD
- ANCHOR 'B'** - 1/2" DIA. SCREW-BOLT+ BY 'DEWALT'
 THRU 1BY OR 2BY WOOD BUCKS INTO CONC.
 2-1/2" MIN. EMBED INTO CONCRETE
 DIRECTLY INTO CONCRETE
 2-1/2" MIN. EMBED INTO CONCRETE
- ANCHOR 'C'** - 1/2" DIA. TAP-FLEX SCREWS BY 'DEWALT' (GRADE 5 CRS)
 INTO F.B.C. APPROVED MULLIONS
 OR
 INTO METAL STRUCTURES
 (3) THREADS MIN. PENETRATION BEYOND SUBSTRATE
 ALUMINUM: 1/4" THK. MIN. (6063-T5 MIN.)
 STEEL: 1/4" THK. MIN. (Fy = 36 KSI MIN.)
 (STEEL IN CONTACT WITH ALUMINUM TO BE PLATED OR PAINTED)

TYPICAL EDGE DISTANCE

- INTO CONCRETE = 2-1/2" MIN.
- INTO WOOD STRUCTURE = 2" MIN.
- INTO METAL STRUCTURE = 3/4" MIN.
- WOOD AT HEAD OR SILL SG = 0.55 MIN.
- CONCRETE AT HEAD OR SILL f'c = 3000 PSI MIN.

JAMB ANCHORS: SEE ELEV. FOR SPACING

- 5/16" DIA. ULTRACON BY 'DEWALT' (Fu=177 KSI, Fy=155 KSI)
 INTO 2BY WOOD BUCKS OR WOOD STRUCTURES
 1-1/2" MIN. PENETRATION INTO WOOD
 THRU 1BY BUCKS INTO CONC. OR BLOCKS
 1-1/4" MIN. EMBED INTO CONCRETE
 1-1/4" MIN. EMBED INTO BLOCKS
 DIRECTLY INTO CONCRETE OR BLOCKS
 1-1/4" MIN. EMBED INTO CONCRETE
 1-3/4" MIN. EMBED INTO GROUT-FILLED BLOCKS
- 5/16" DIA. TEKS OR SELF DRILLING SCREWS (GRADE 5 CRS)
 INTO F.B.C. APPROVED MULLIONS
 AND
 INTO METAL STRUCTURES
 (3) THREADS MIN. TO EXTEND BEYOND METAL THICKNESS
 ALUMINUM: 1/4" THK. MIN. (6063-T5 MIN.)
 STEEL: 1/4" THK. MIN. (Fy = 36 KSI MIN.)
 (STEEL IN CONTACT WITH ALUMINUM TO BE PLATED OR PAINTED)

CRITICAL EDGE DISTANCE

- INTO CONCRETE AND BLOCKS = 2-1/2" MIN.
- INTO WOOD STRUCTURE = 1" MIN.
- INTO METAL STRUCTURE = 3/4" MIN.
- WOOD AT HEAD, SILL OR JAMBS SG = 0.55 MIN.
- CONCRETE AT HEAD, SILL OR JAMBS f'c = 3000 PSI MIN.
- C-90 HOLLOW/FILLED BLOCK AT JAMBS f'm = 2000 PSI MIN.

WOOD BUCKS AND METAL STRUCTURE NOT BY 'FAOUR GLASS'
 MUST SUSTAIN LOADS IMPOSED BY GLAZING SYSTEM
 AND TRANSFER THEM TO THE BUILDING STRUCTURE.

Sealed: 2/16/2021

FL #25673

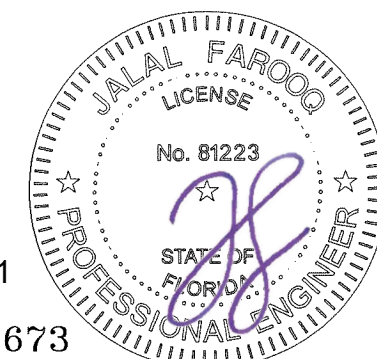

af c
AL-FAROOQ CORPORATION
 ENGINEERS & PRODUCT DEVELOPMENT
 9360 SUNSET DRIVE, SUITE 220 (C.A.N. 3588)
 MIAMI, FLORIDA 33173 FAX. (305) 262-6978
 TEL. (305) 264-8100 COMP-ANL \ 21-07F-FGT

SERIES 'SLIMPACT XJ' GLASS WALL SYSTEM (L.M.I.)
Faour Glass Technologies
 5119 West Knox Street
 Tampa, FL 33634
 Tel. (813) 884-3297 Fax. (-)

revisions:	no	date	by	description

date: 01-25-21
 scale: 3/8" = 1"
 dr. by: TARIQ
 chk. by:

drawing no.
21-07F

sheet 3 of 6

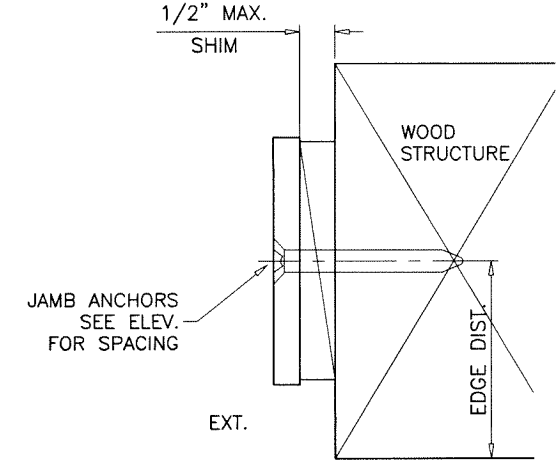
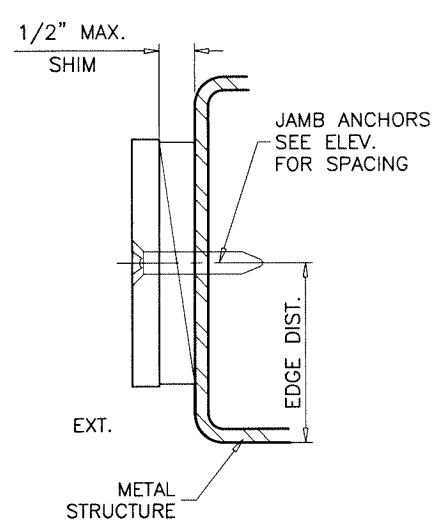
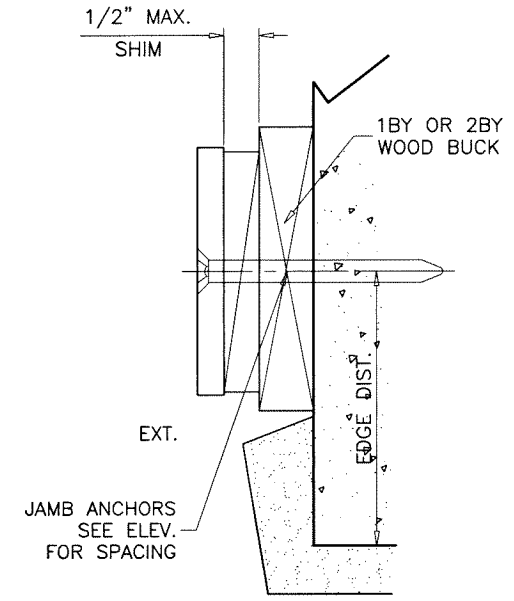
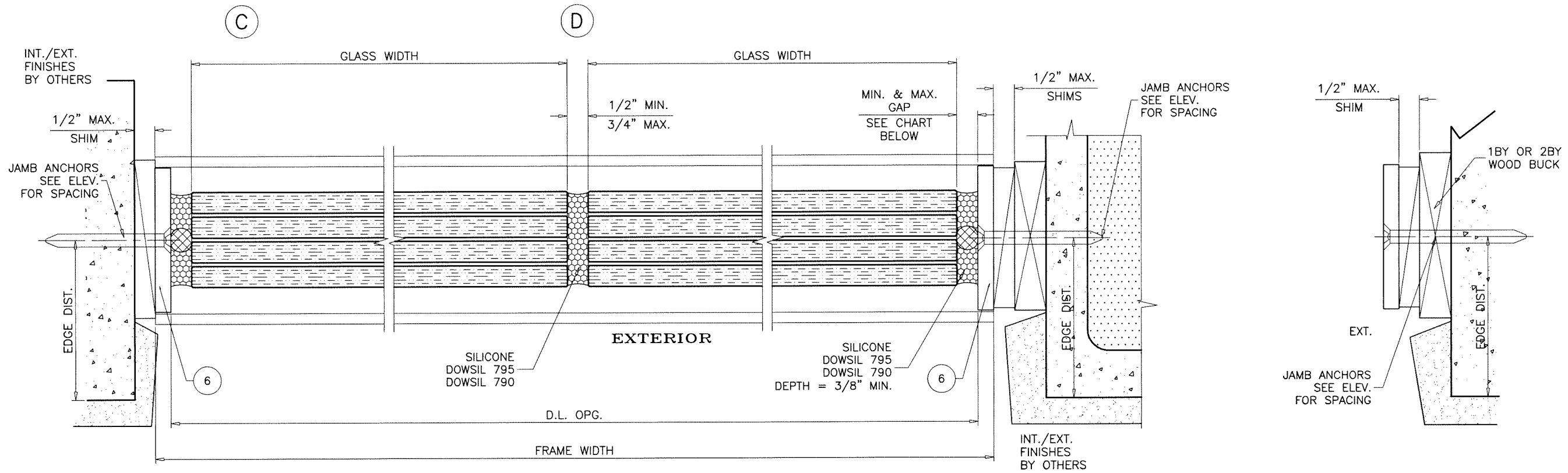

D.L.O. DIMS.		DESIGN LOAD PSF	GAP			
WIDTH	HEIGHT		DOWSIL 795		DOWSIL 790	
			MIN.	MAX.	MIN.	MAX.
118"	234"	65.0	-	-	1.36"	1.38"
		60.0	-	-	1.25"	1.38"
		50.0	-	-	1.04"	1.38"
121-1/8"	228"	66.7	-	-	1.26"	1.38"
		60.0	-	-	1.13"	1.38"
		50.0	-	-	.95"	1.38"
127-7/8"	216"	70.4	-	-	1.08"	1.38"
		60.0	-	-	.92"	1.38"
		50.0	1.19"	1.38"	.77"	1.38"
135-3/8"	204"	74.6	-	-	.92"	1.38"
		70.0	1.34"	1.38"	.86"	1.38"
		60.0	1.15"	1.38"	.74"	1.38"
143-13/16"	192"	79.2	1.2"	1.38"	.78"	1.38"
		70.0	1.06"	1.38"	.69"	1.38"
		60.0	.91"	1.38"	.59"	1.38"
153-7/16"	180"	84.5	1.0"	1.38"	.65"	1.38"
		80.0	.95"	1.38"	.61"	1.38"
		70.0	.83"	1.38"	.54"	1.38"
163-3/8"	169"	90.0	.84"	1.38"	.54"	1.38"
		80.0	.75"	1.38"	.48"	1.38"
		70.0	.66"	1.38"	.42"	1.38"
		60.0	.56"	1.38"	.36"	1.38"
		50.0	.47"	1.38"	.30"	1.38"

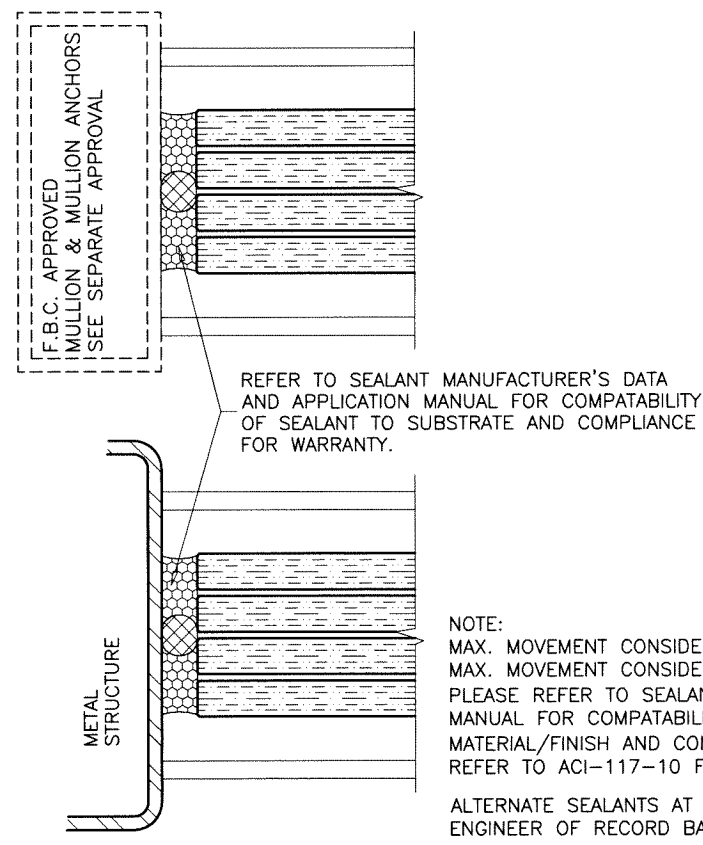

NOTE:
 MAX. MOVEMENT CONSIDERED=50% STRETCH FOR DOWSIL 795.
 MAX. MOVEMENT CONSIDERED=100% STRETCH FOR DOWSIL 790.
 PLEASE REFER TO SEALANT MANUFACTURER'S DATA AND APPLICATION MANUAL FOR COMPATIBILITY OF SEALANT TO SUBSTRATE & WINDOW WALL MATERIAL/FINISH AND COMPLIANCE FOR WARRANTY.
 REFER TO ACI-117-10 FOR CONSTRUCTION TOLERANCES.
 ALTERNATE SEALANTS AT JAMB GAPS CAN BE DESIGNED BY ENGINEER OF RECORD BASED ON MANUFACTURER GUIDE LINES.

Sealed: 2/16/2021

FL #25673

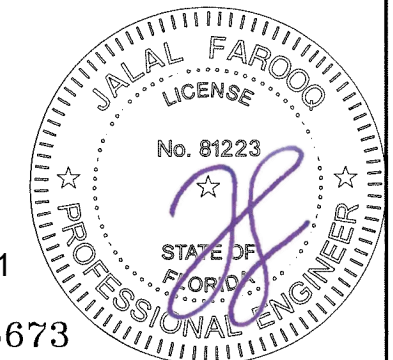

af c
AL-FAROOQ CORPORATION
 ENGINEERS & PRODUCT DEVELOPMENT
 9360 SUNSET DRIVE, SUITE 220
 MIAMI, FLORIDA 33173
 TEL. (305) 264-8100 FAX. (305) 262-6978
 (C.A.N. 3538)
 COMP-ANL\21-07F-FGT

SERIES 'SLIMPACT XJ' GLASS WALL SYSTEM (L.M.I.)
Faour Glass Technologies
 5119 West Knox Street
 Tampa, FL. 33634
 Tel. (813) 884-3297 Fax. (-)

revisions:	no	date	description
date:	01-25-21	scale:	3/8" = 1"
dr. by:	TARIQ	chk. by:	
drawing no.	21-07F		
sheet	4 of 6		

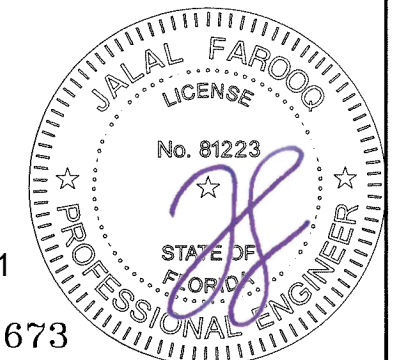
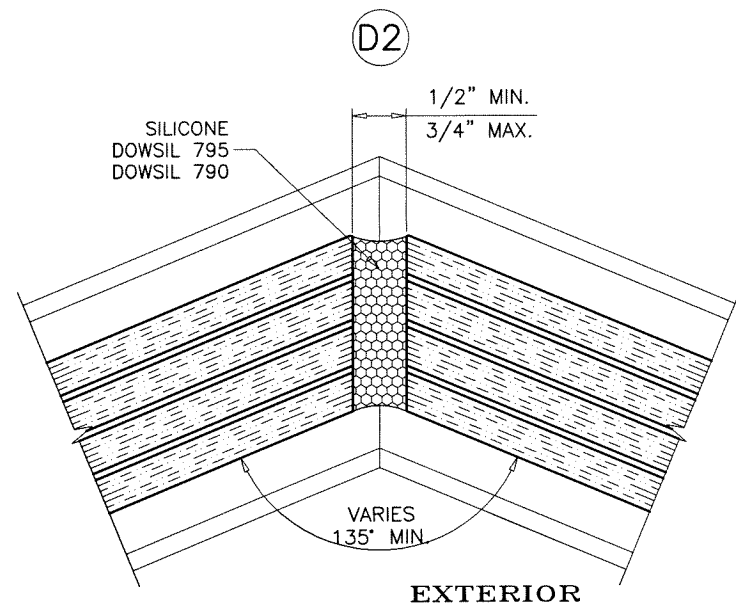
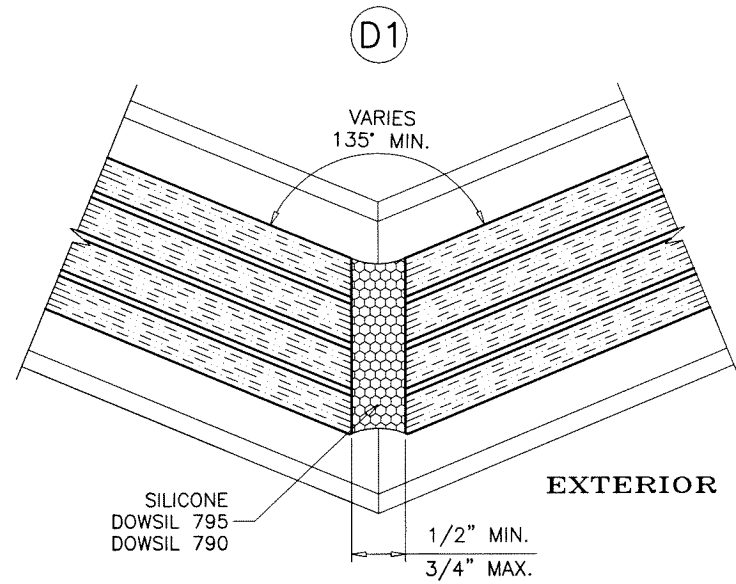

Sealed: 2/16/2021

FL #25673

afc

AL-FAROOQ CORPORATION
 ENGINEERS & PRODUCT DEVELOPMENT
 9360 SUNSET DRIVE, SUITE 220 (C.A.N. 3538)
 MIAMI, FLORIDA 33173 TEL. (305) 264-8100 FAX. (305) 262-6978
 COMP-ANL\21-07F-FGT

SERIES 'SLIMPACT XJ' GLASS WALL SYSTEM (L.M.I.)

Faour Glass Technologies
 5119 West Knox Street
 Tampa, FL, 33634
 Tel. (813) 884-3297 Fax. (-)

revisions:	
no	date by description

date: 01-25-21	scale: 3/8" = 1"
dr. by: TARIQ	chk. by:

drawing no.
21-07F

sheet 5 of 6

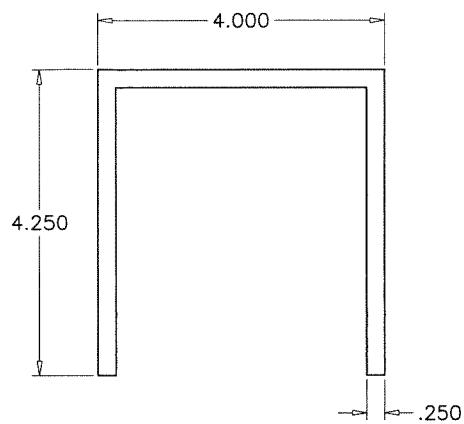

1 TOP CHANNEL

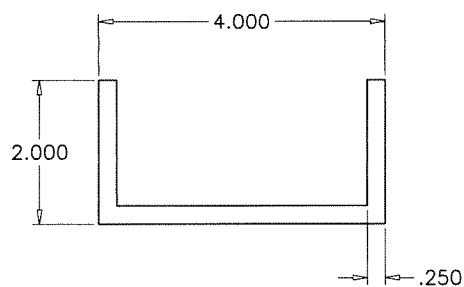

2 BOTTOM CHANNEL

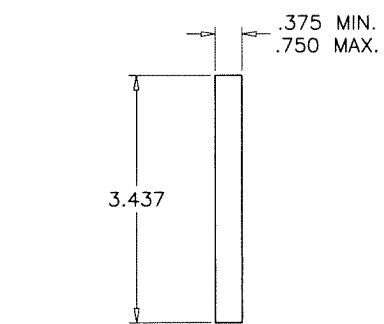

6 SIDE BAR

ITEM #	PART #	REQD.	DESCRIPTION	MATERIAL	MANF./SUPPLIER/REMARKS
1	-	AS REQD.	TOP CHANNEL	6061-T6	-
2	-	AS REQD.	BOTTOM CHANNEL	6061-T6	-
3	-	2/ LITE	SETTING BLOCKS AT 1/4 POINTS, (2-1/2" X 3/4" X 6" LONG)	EPDM	DUROMETER 80±5 SHORE A
4	-	AS REQD.	3/8" DIA. BACKER ROD	FOAM	-
5	DOWSIL 995	AS REQD.	GLAZING COMPOUND	SILICONE	-
6	-	AS REQD.	SIDE BAR	6061-T6	-
7	-	-	-	-	-

SEALANT:

ALL FRAME JOINTS SQUARE-CUT AND BUTTED, SEALED WITH DOWSIL 123 SILICONE SEAL TAPE.

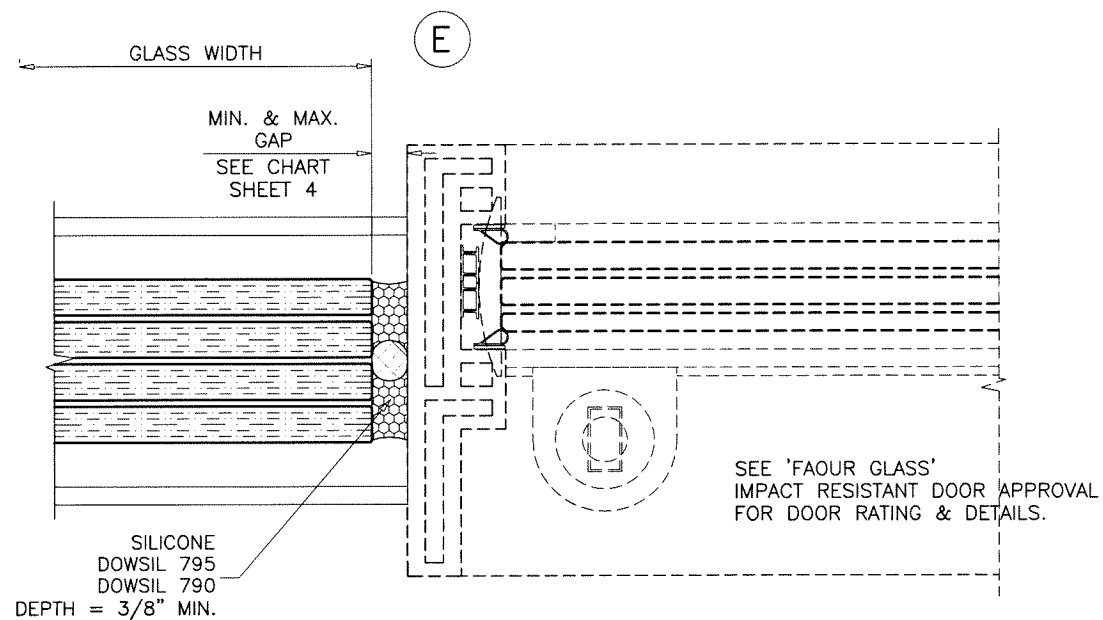

SEE SEPARATE APPROVAL FOR DESIGN LOAD CAPACITY OF DOOR AND DOOR ANCHORS.

LOWER VALUES FROM DOOR APPROVAL OR GLASS WALL SYSTEM CAPACITY WILL APPLY TO ENTIRE SYSTEM.

Sealed: 2/16/2021

FL #25673

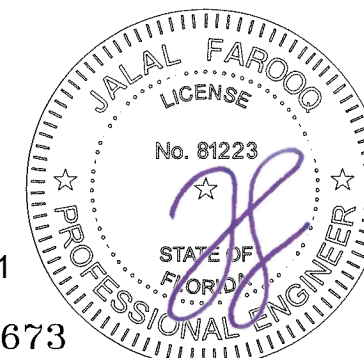

SERIES 'SLIMPACT XJ' GLASS WALL SYSTEM (L.M.I.)

Faour Glass Technologies

5119 West Knox Street
Tampa, FL. 33634

Tel. (813) 884-3297 Fax. (-)

revisions:		date:	scale:	dr. by:	chk. by:
no	date	01-25-21	3/8" = 1"	TARIQ	
	by description				

drawing no. 21-07F
sheet 6 of 6

af c
AL-FAROOQ CORPORATION
ENGINEERS & PRODUCT DEVELOPMENT
9360 SUNSET DRIVE, SUITE 220
MIAMI, FLORIDA 33173 (C.A.N. 3538)
TEL. (305) 264-8100 FAX. (305) 262-6978
COMP-ANL\21-07F-FGT